

Thule Panorama 9200

› Instructions

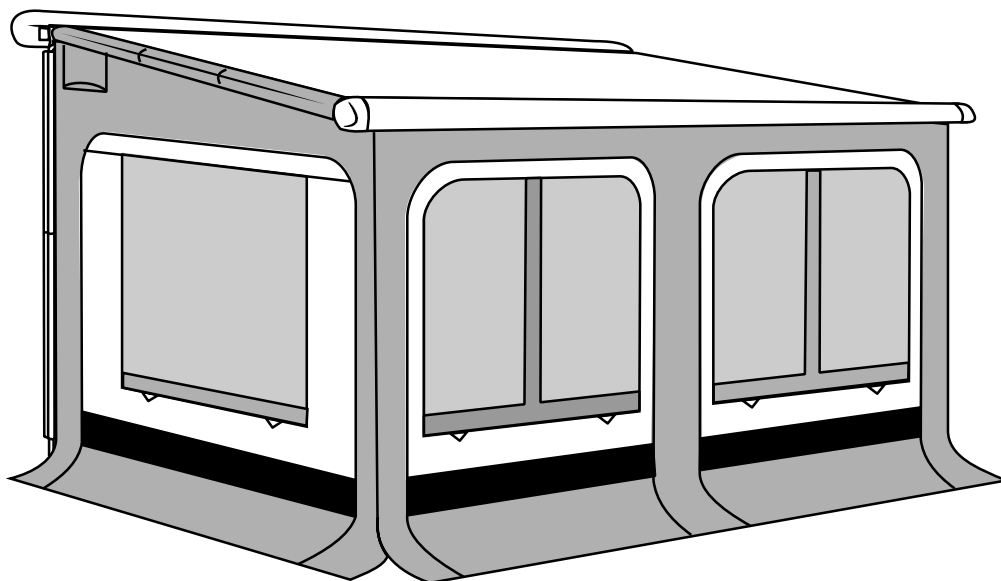

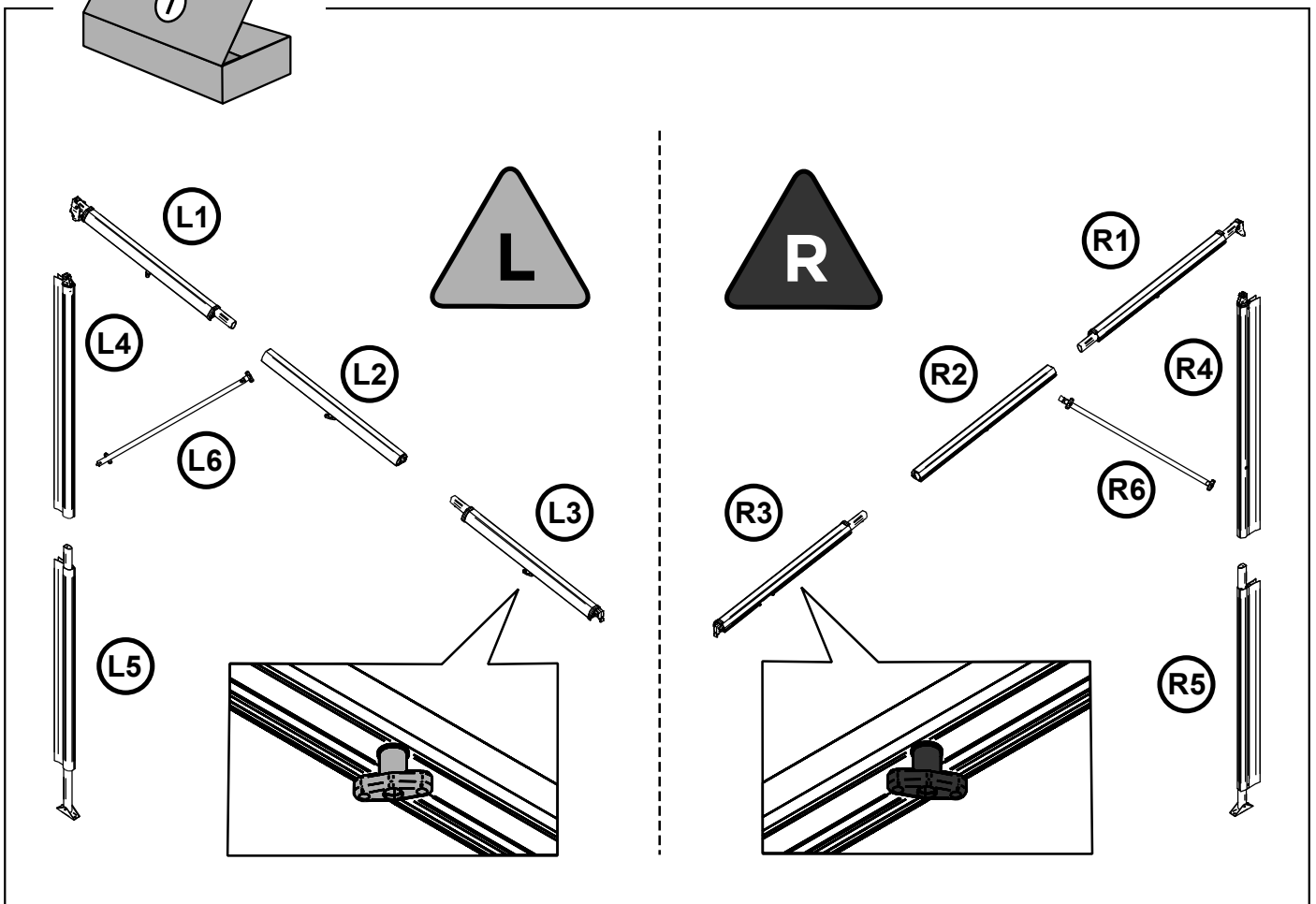

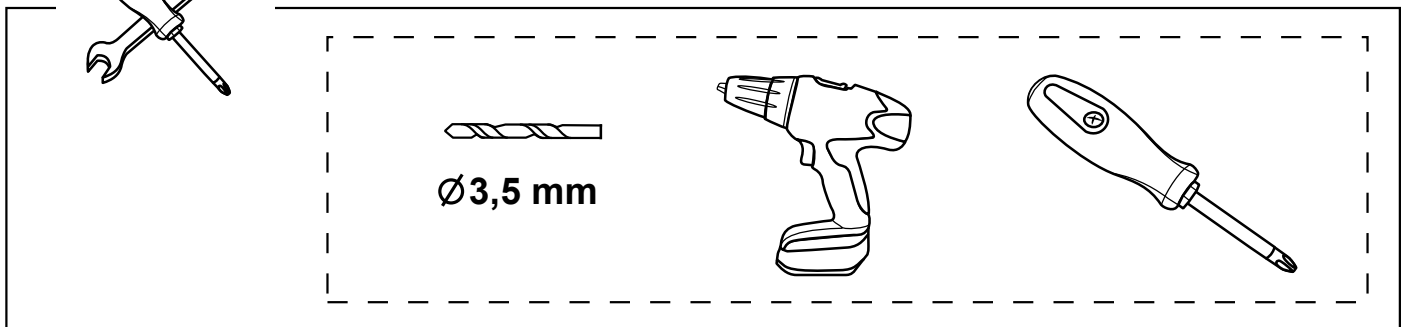
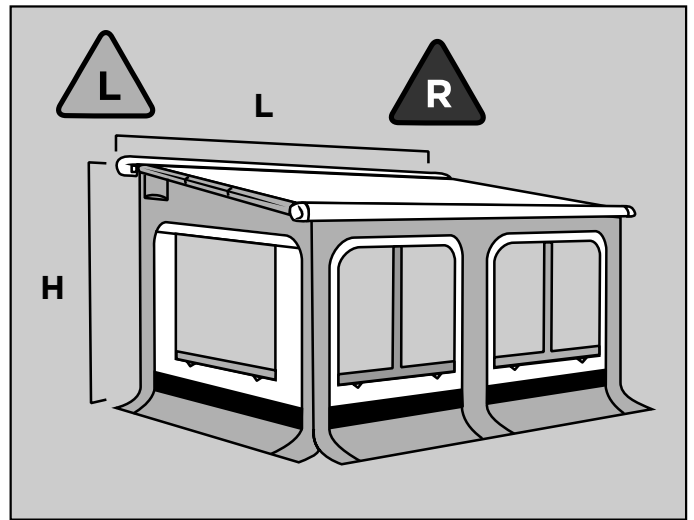
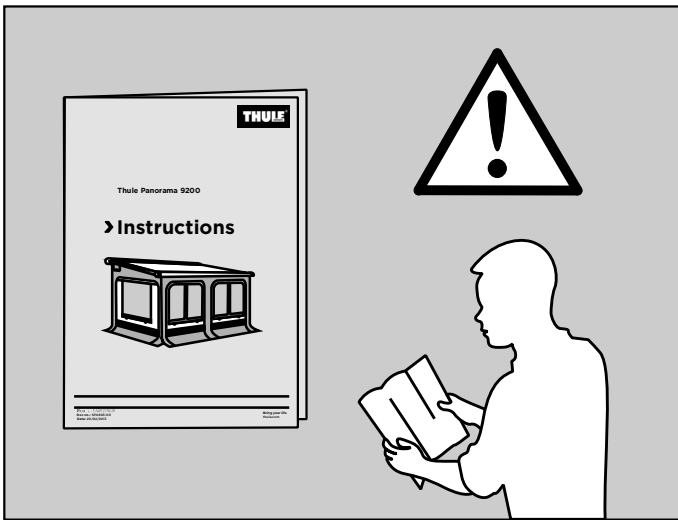
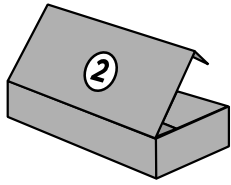

ⓓ

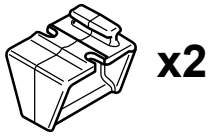

ⓔ

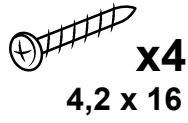

ⓕ

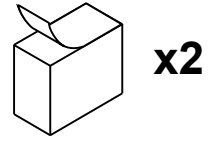

Ⓢ



Ⓣ

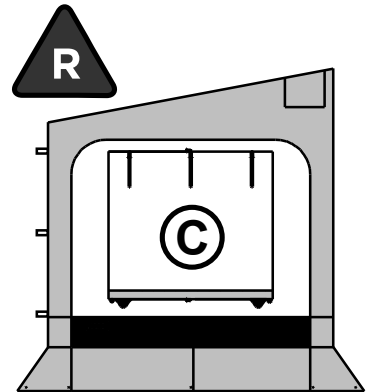
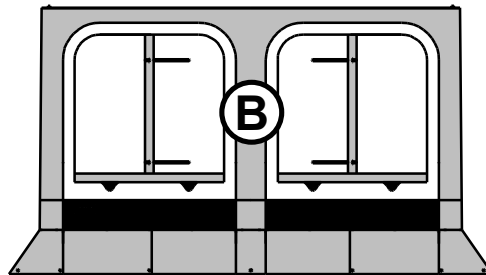
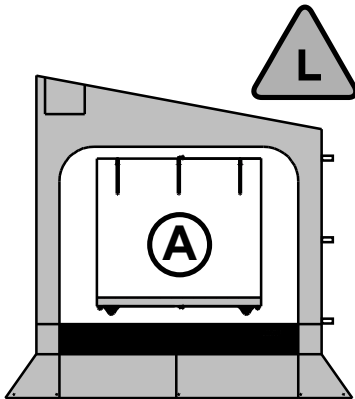
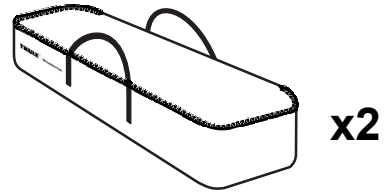

| L | Ⓜ | Ⓝ | Ⓞ | Ⓟ |
|-------------------|------|------|------|------|
| | | | | |
| 3m00 ↓ 6m00 | x 44 | x 44 | x 44 | x 49 |

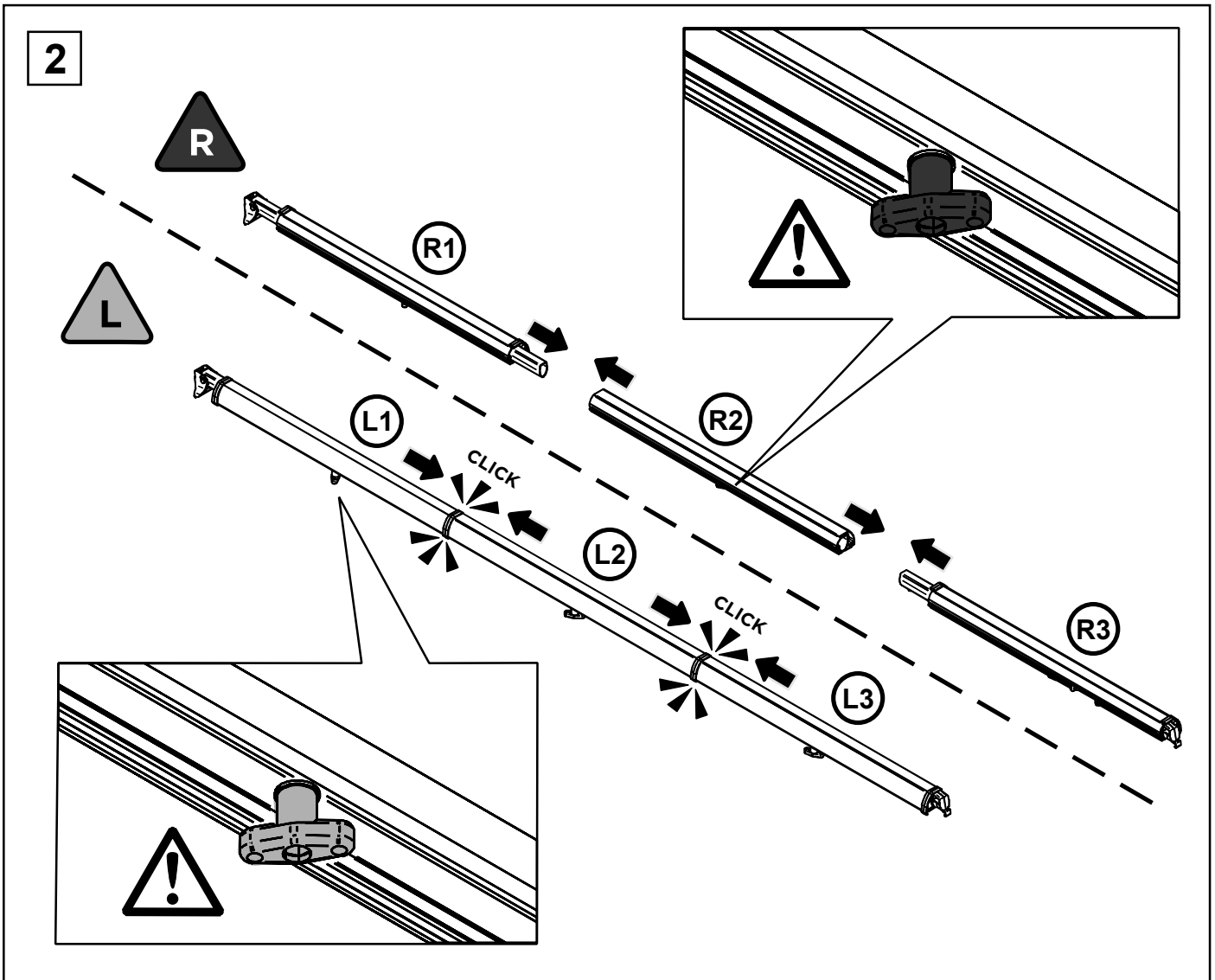
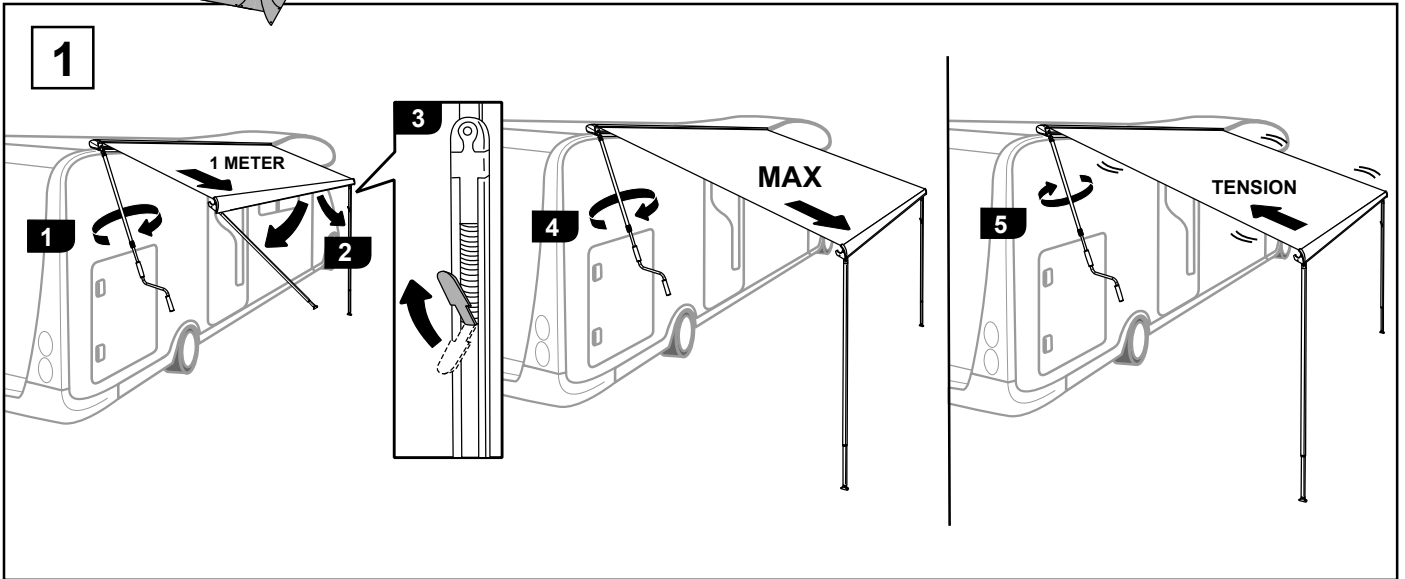
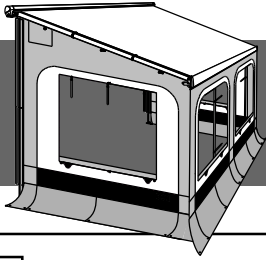

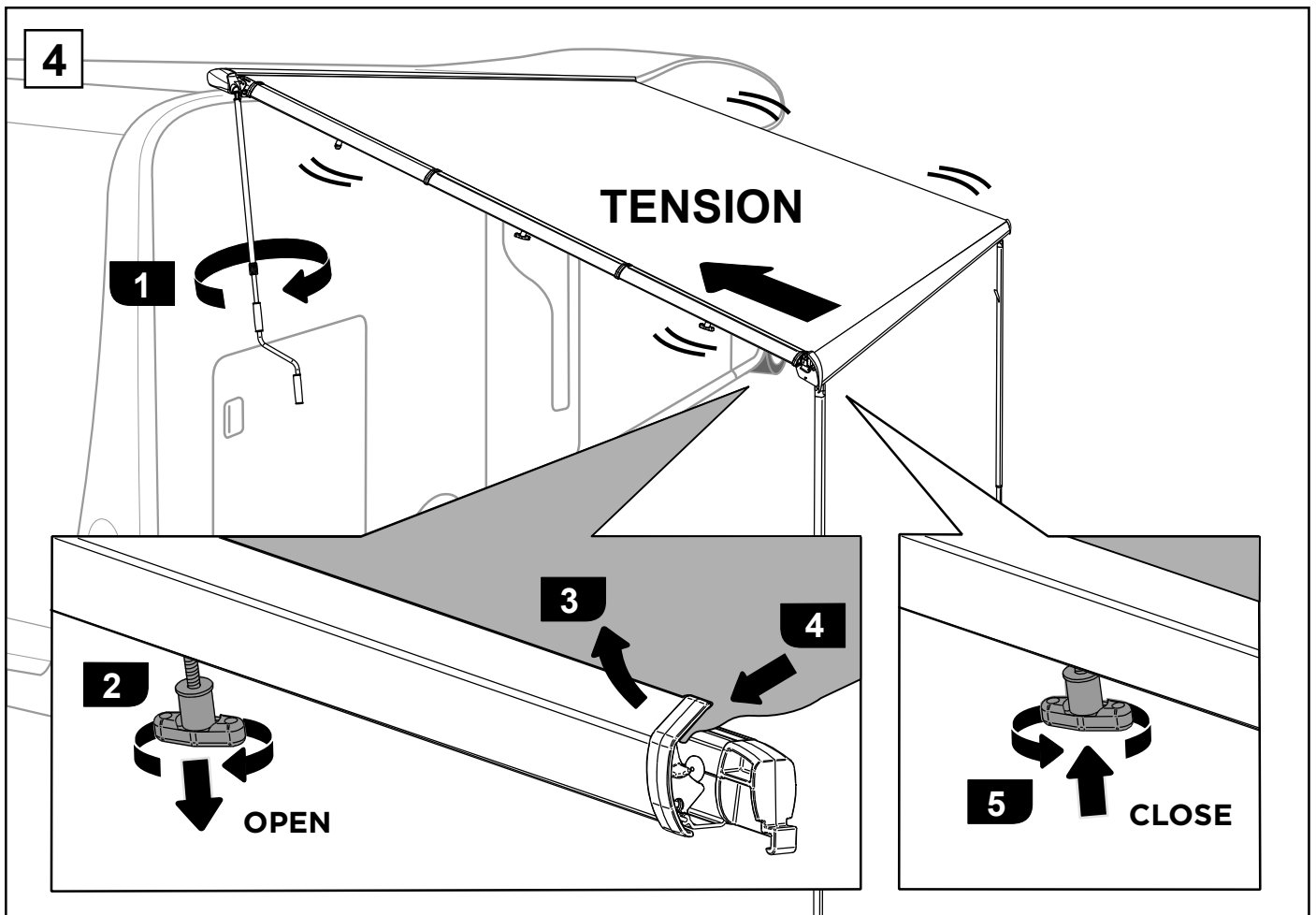
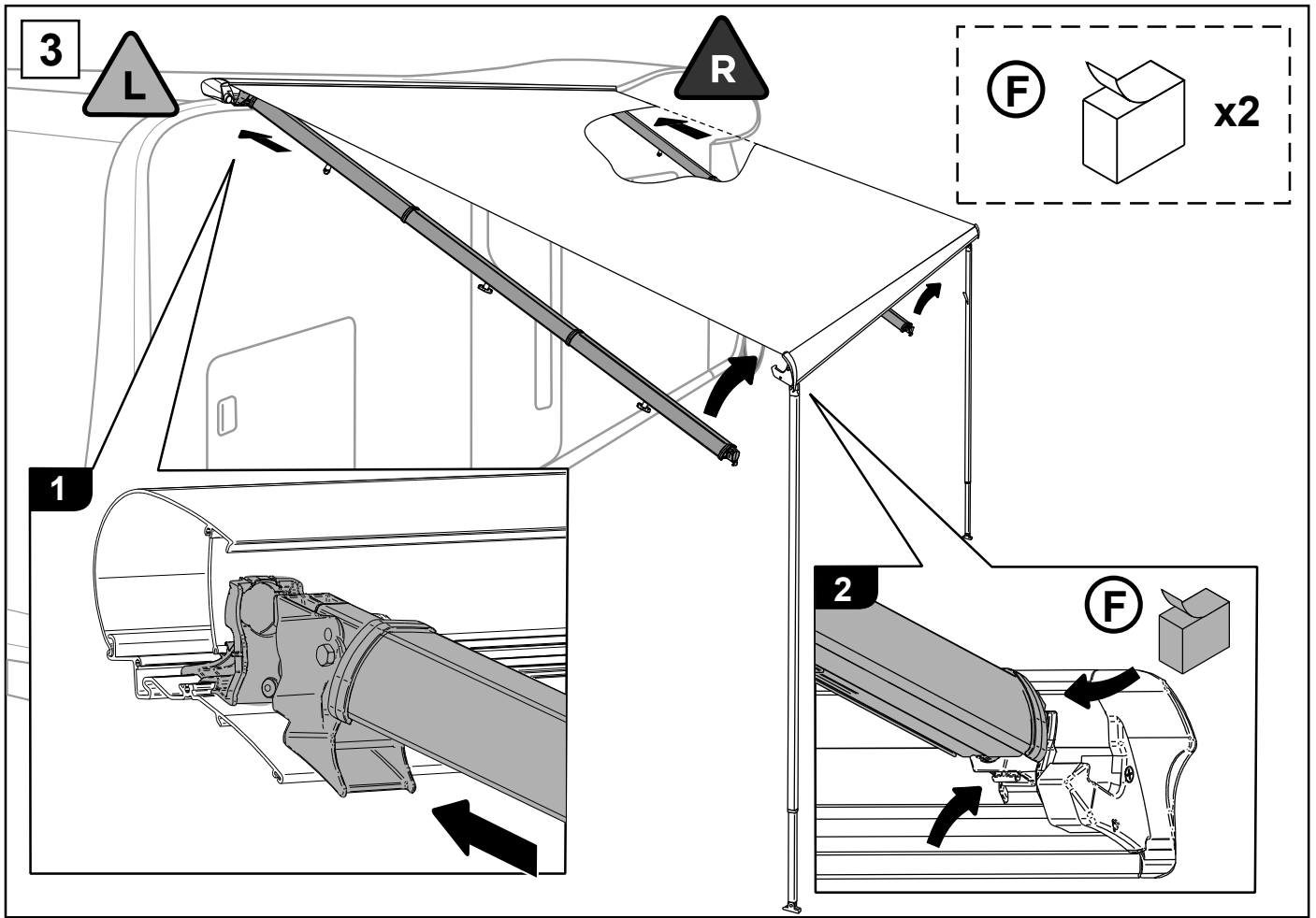

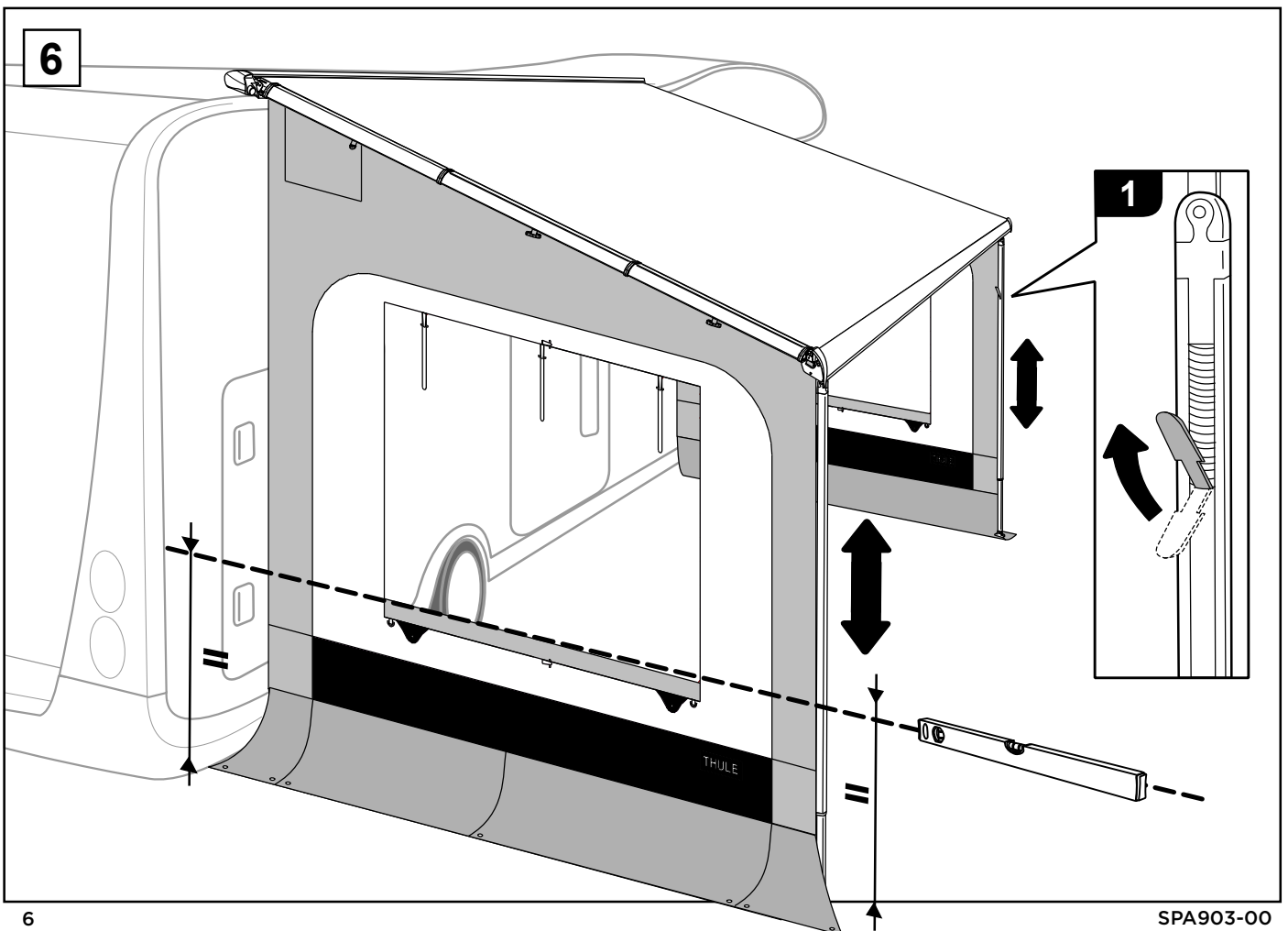
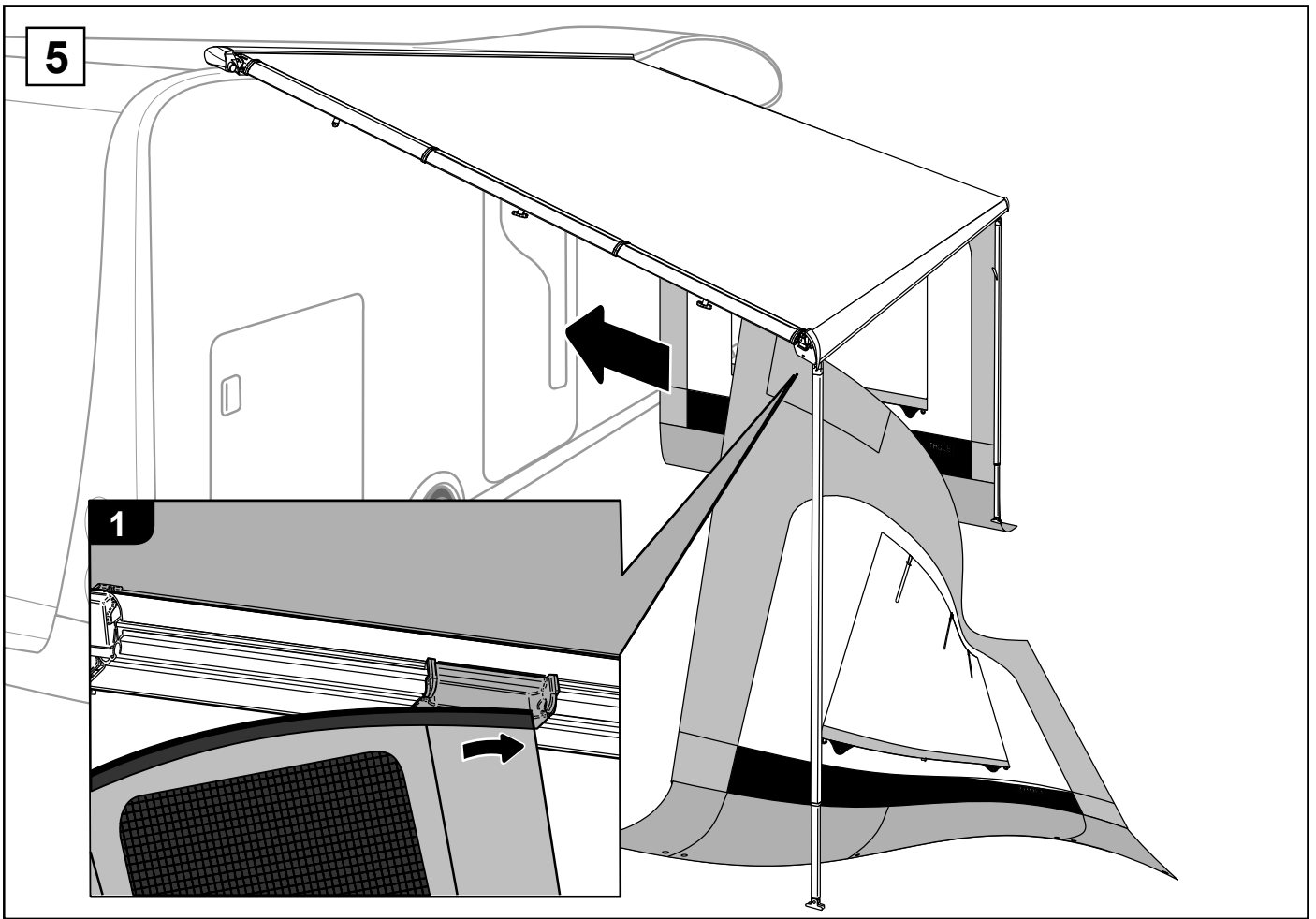

7

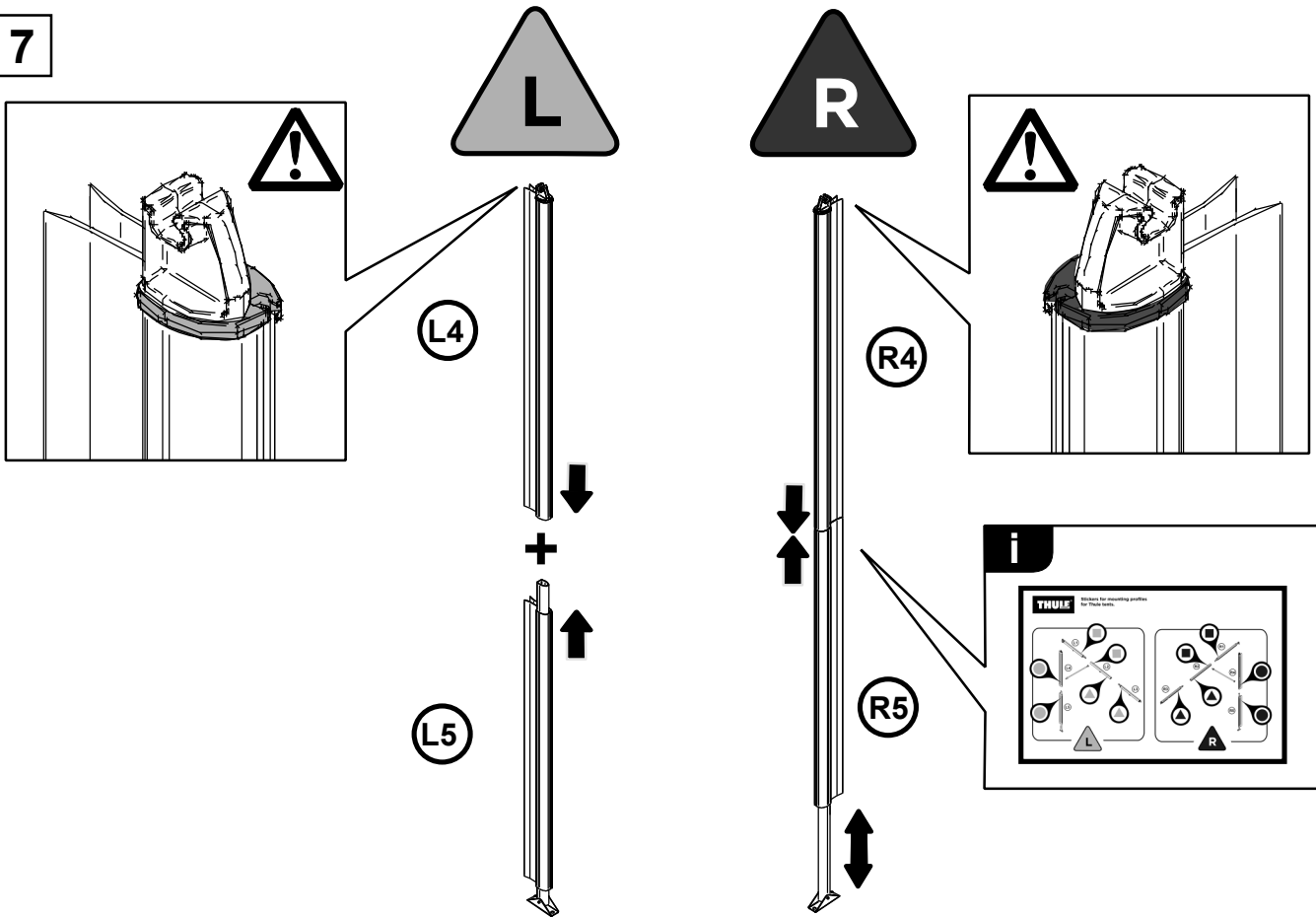

8

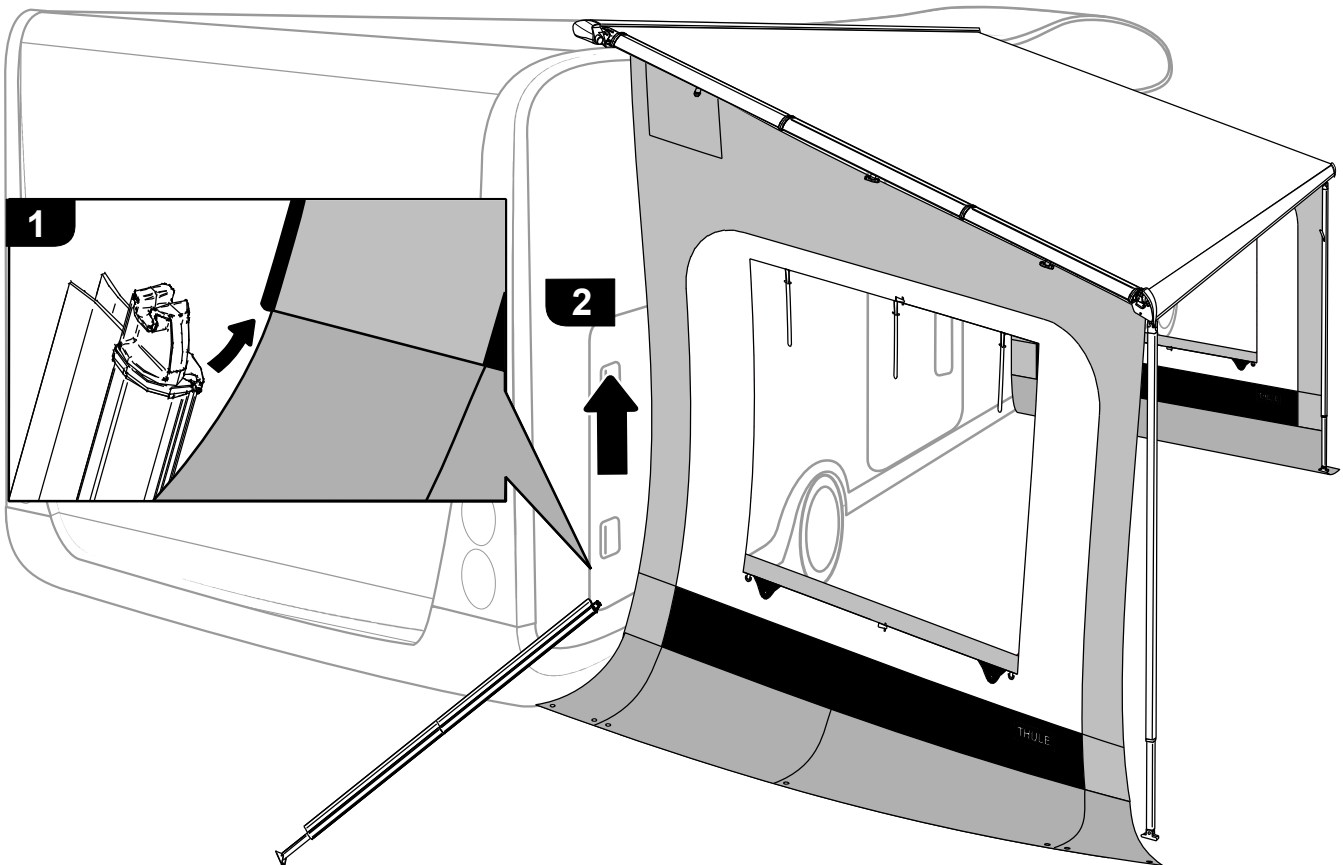

9

D

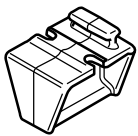

x2

!

L

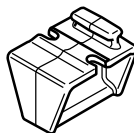

R

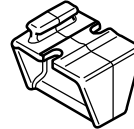

1

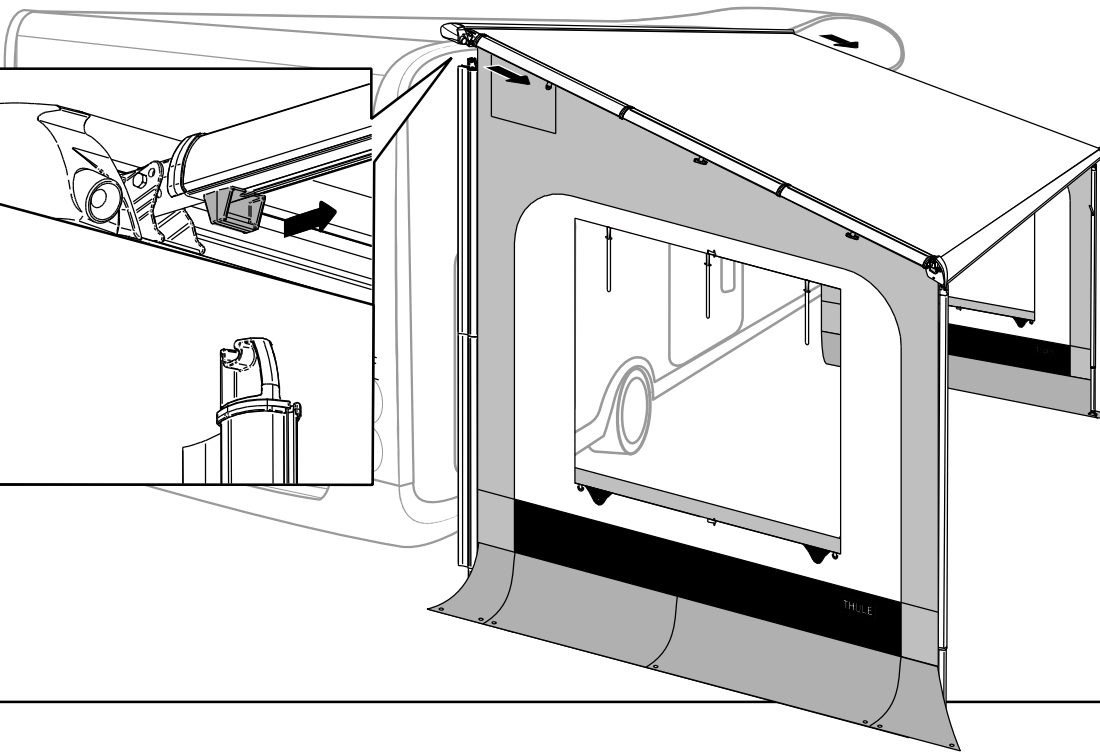
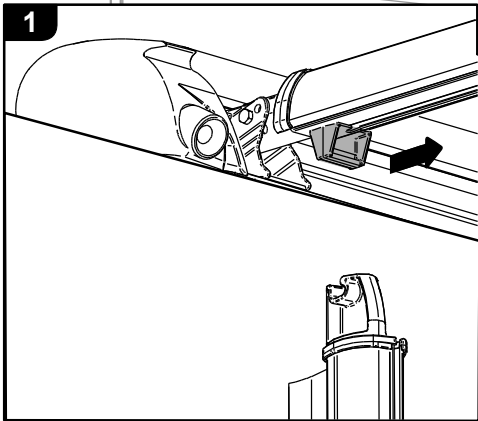

10

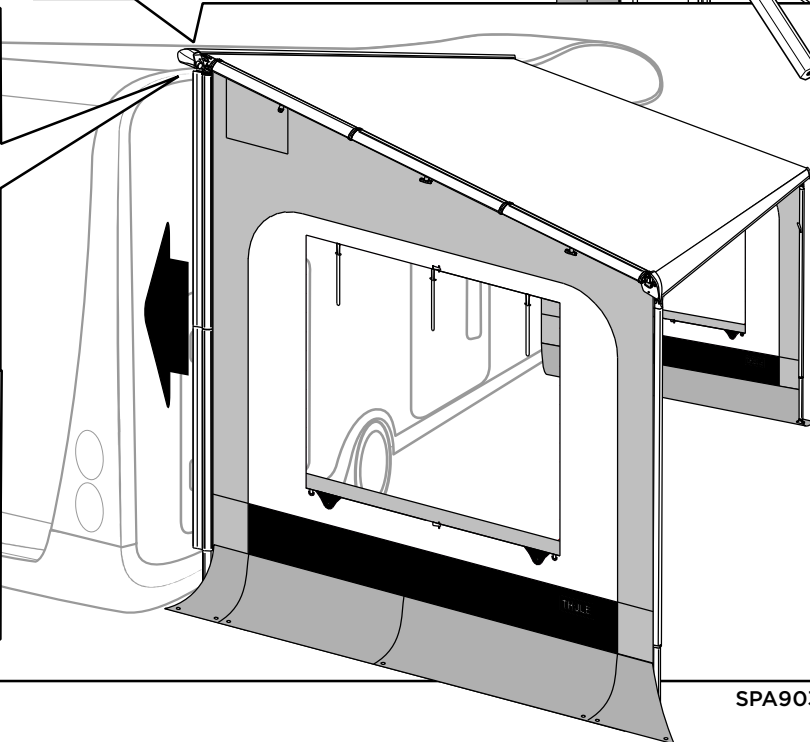
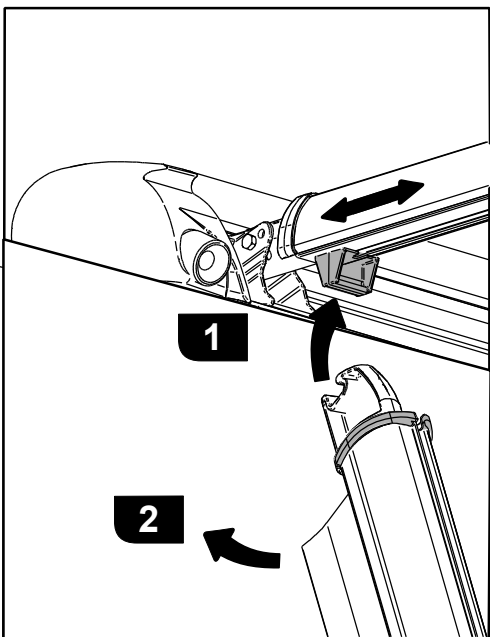
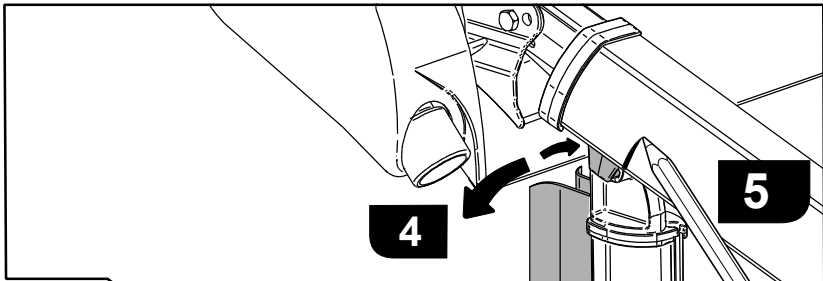

11

ⓔ x4
4,2 x 16

2

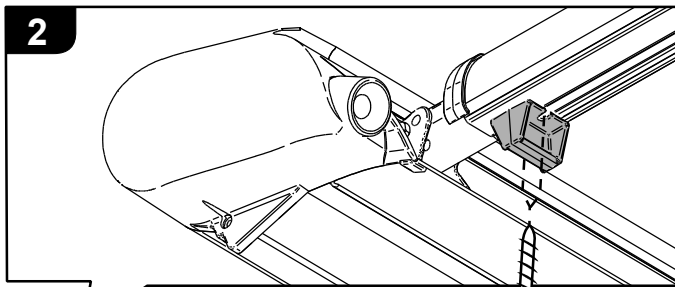

1

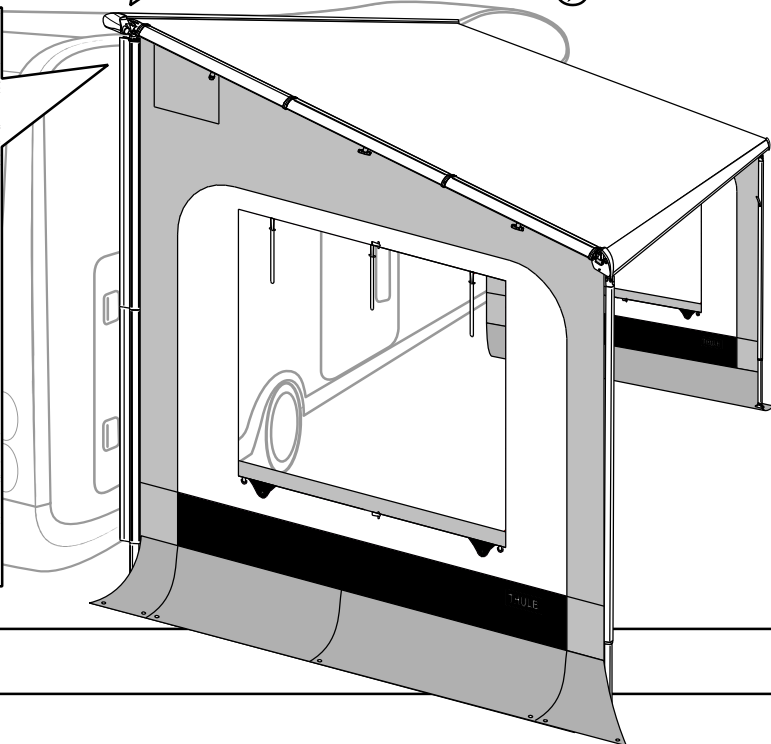
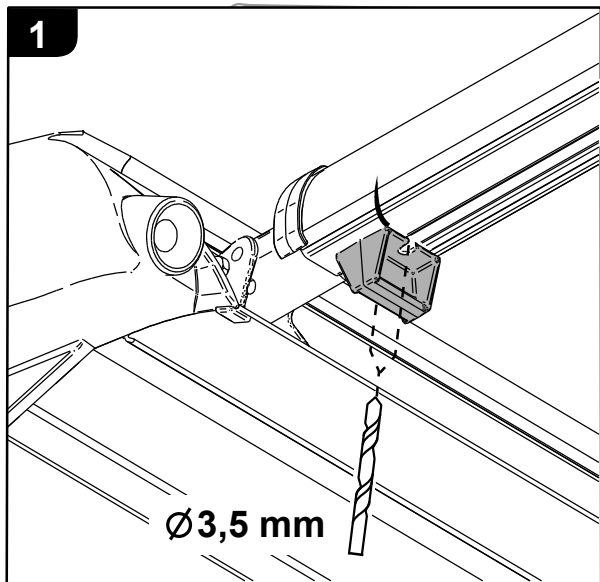

12

1



2

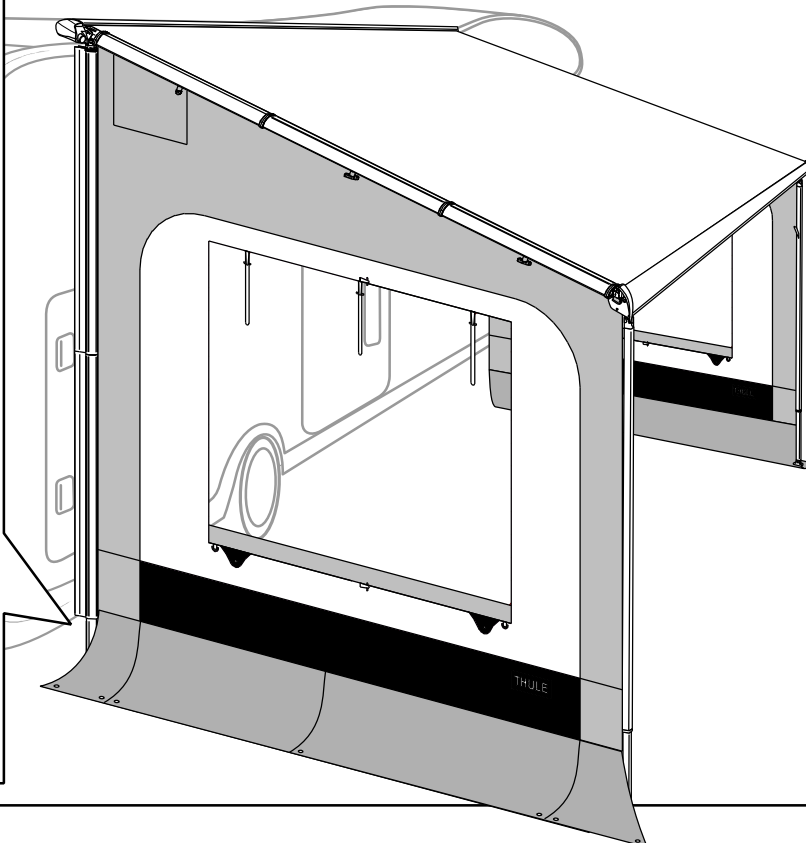
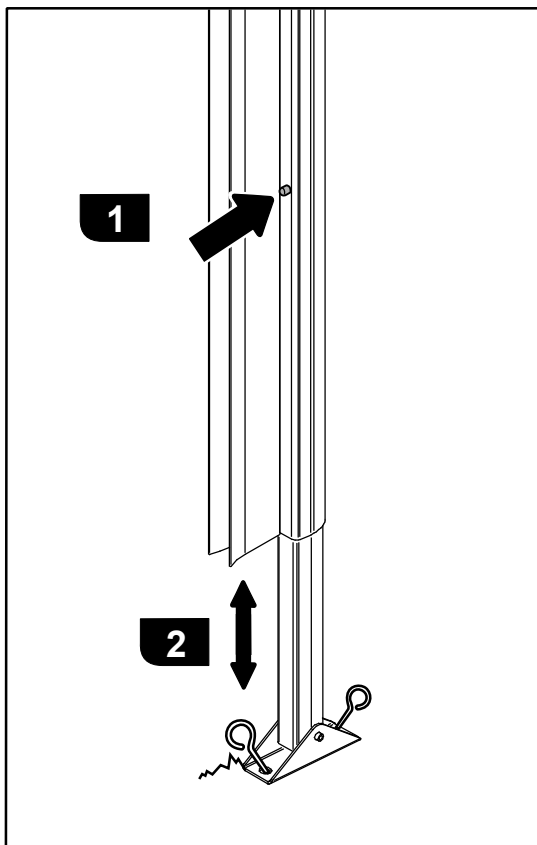

13

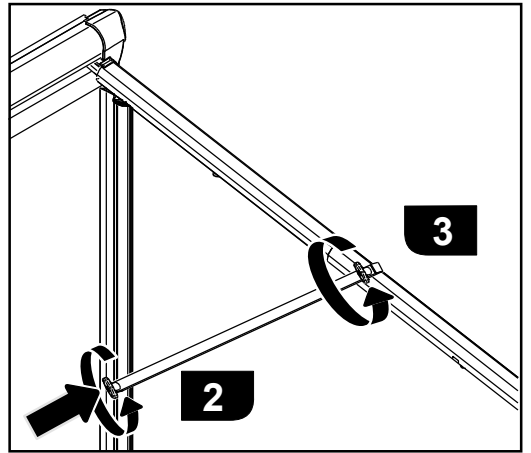
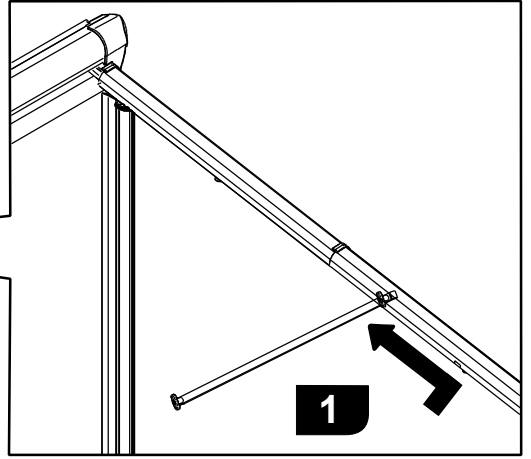
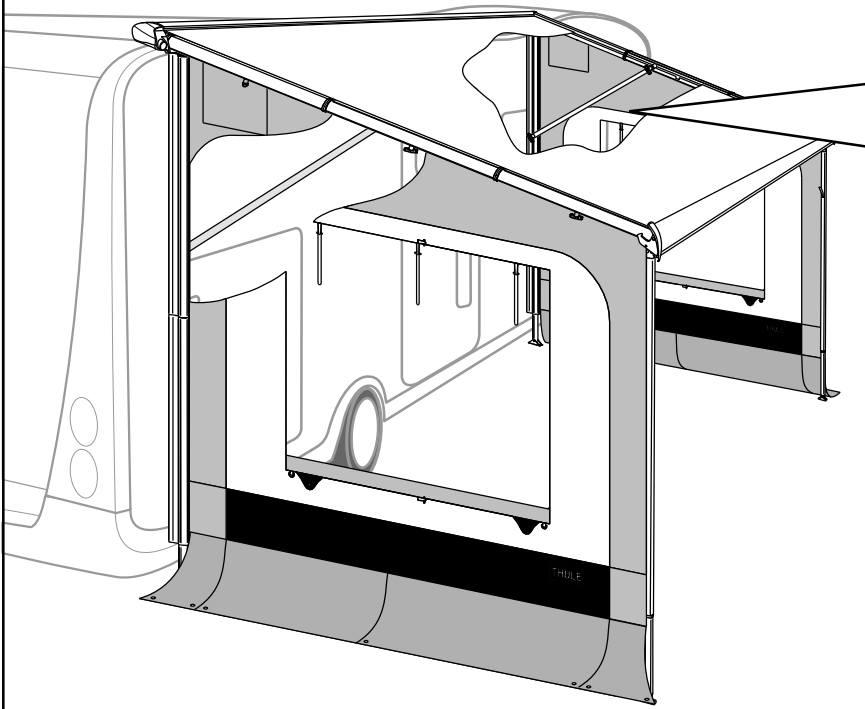

14

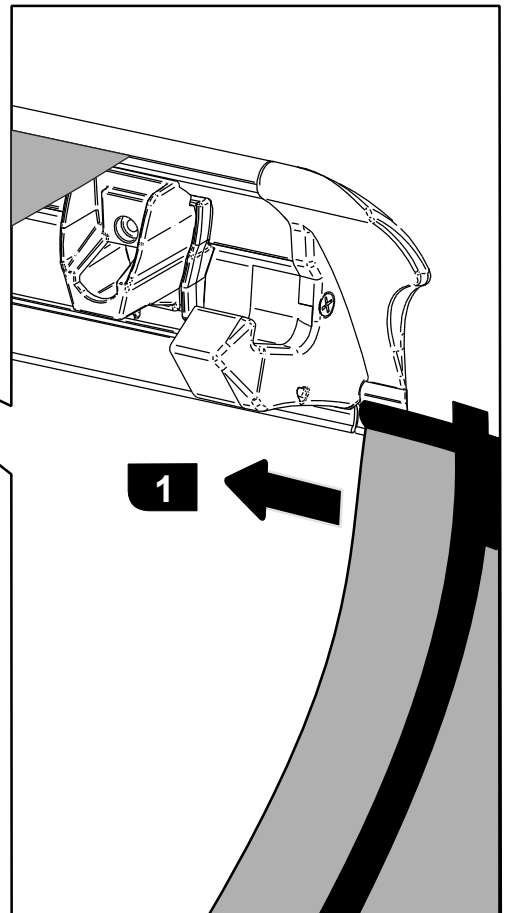
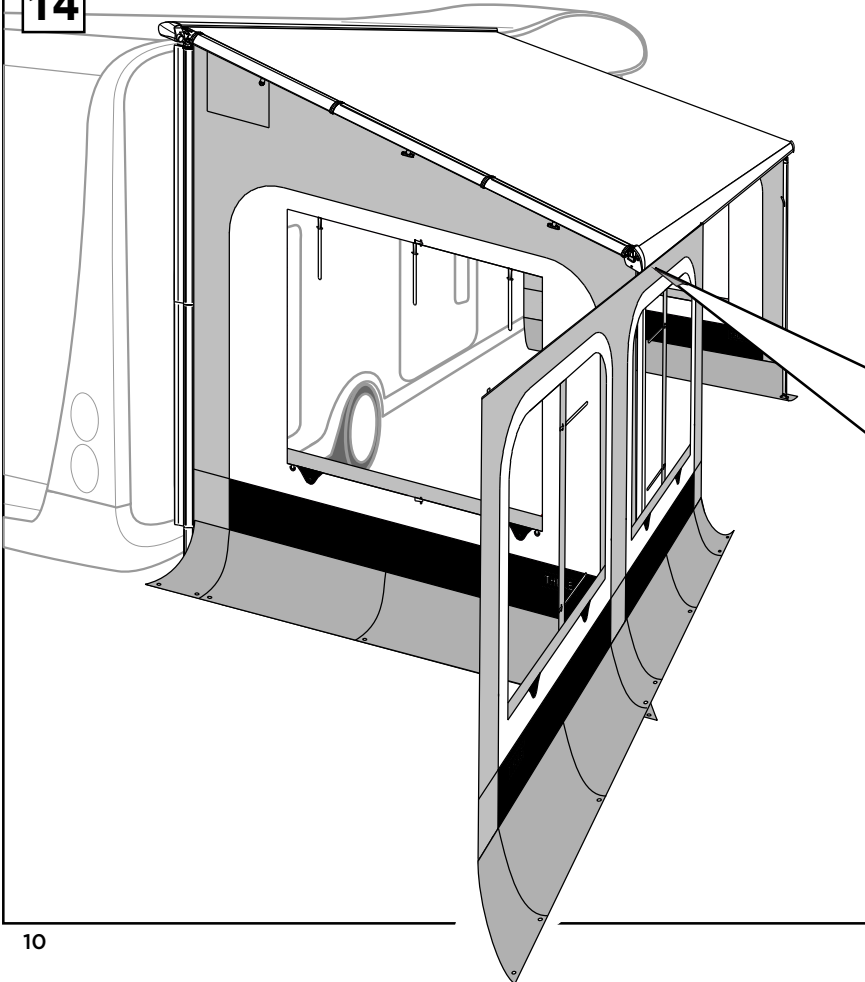

15

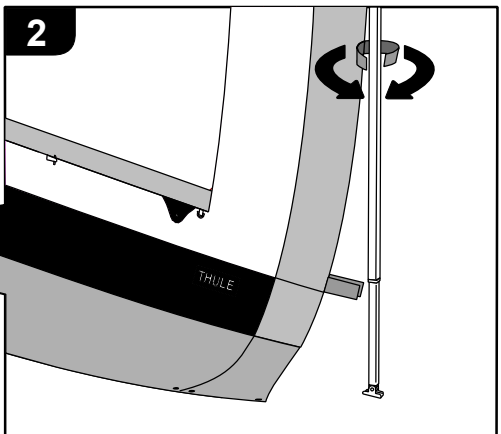
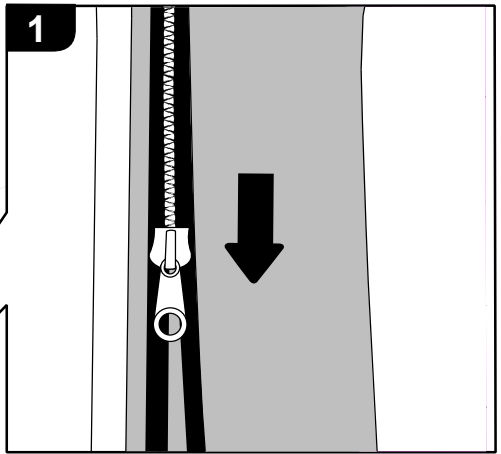
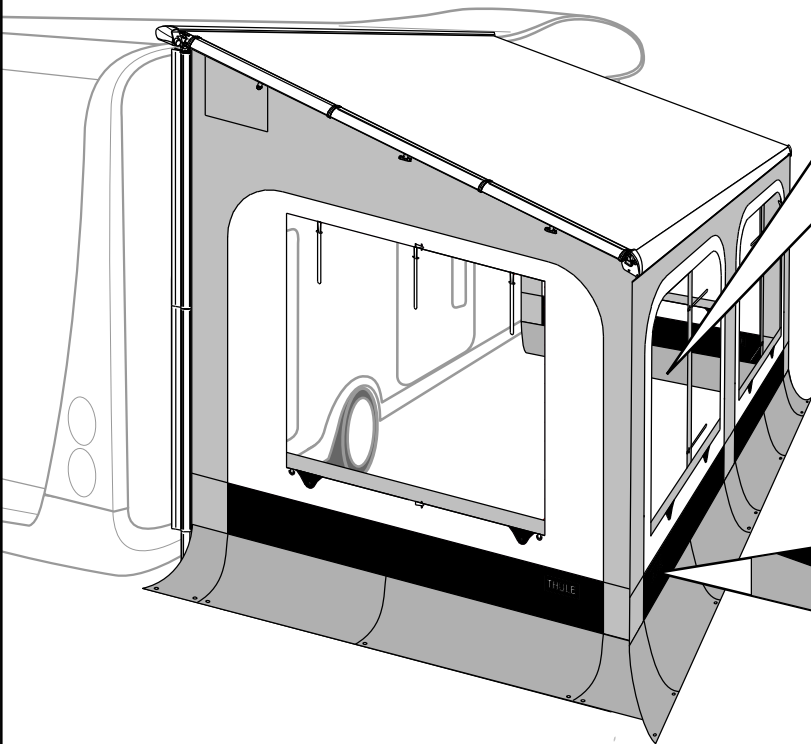

16

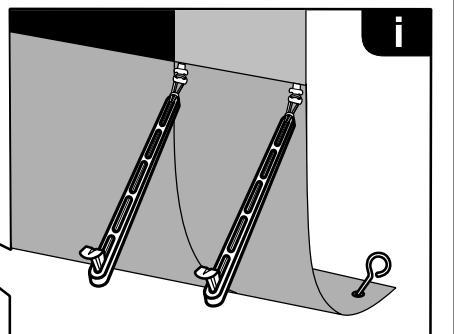
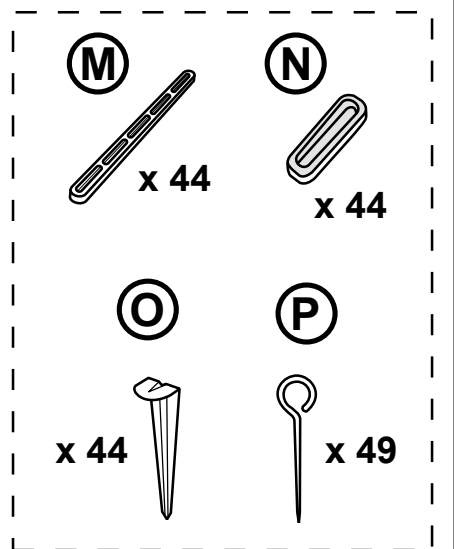
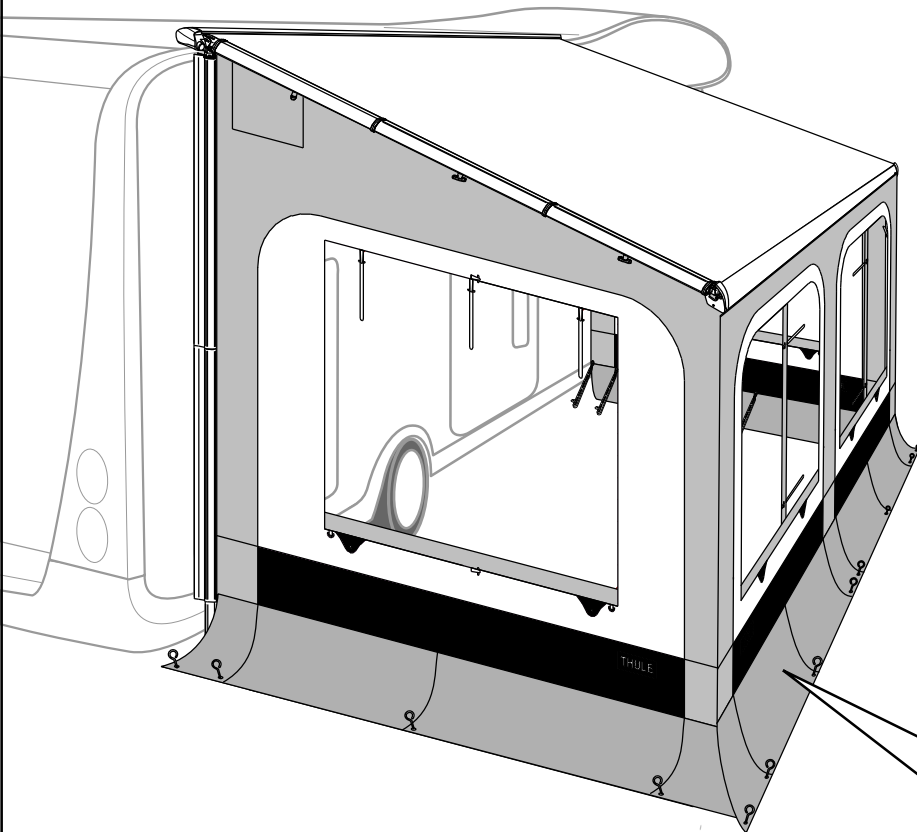

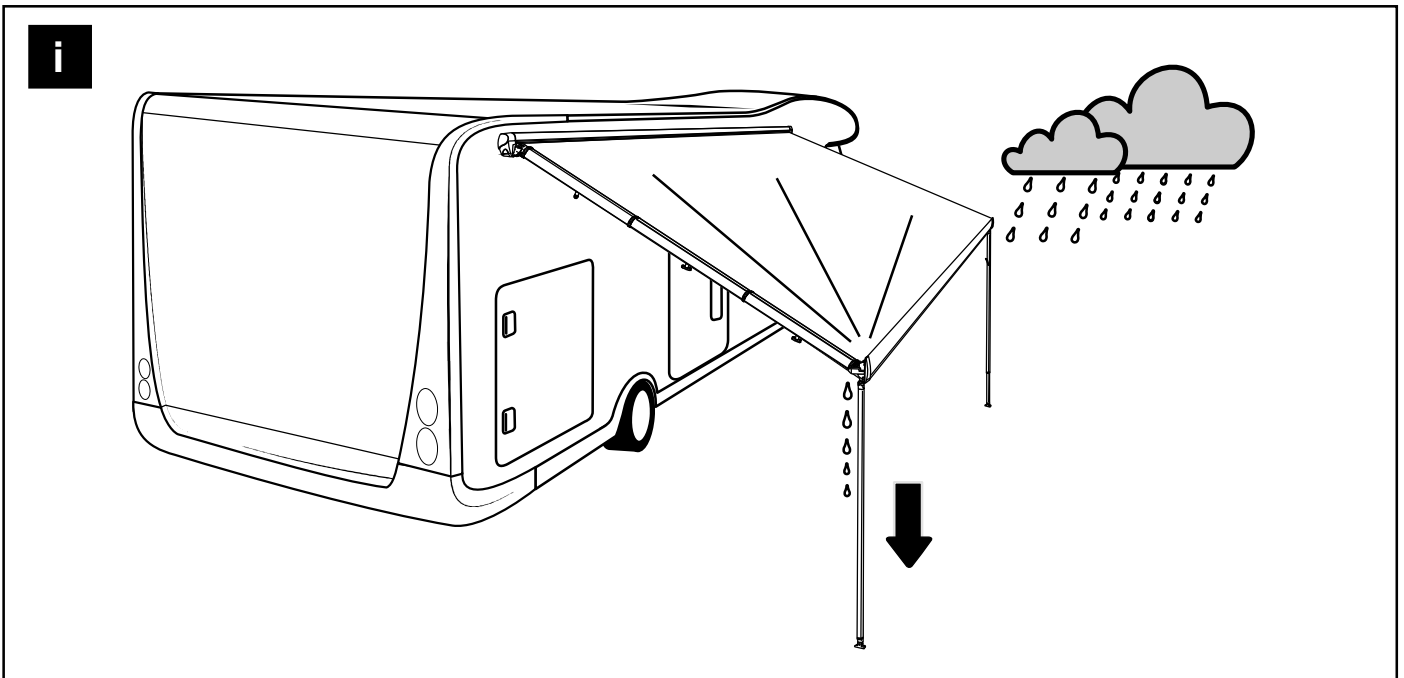
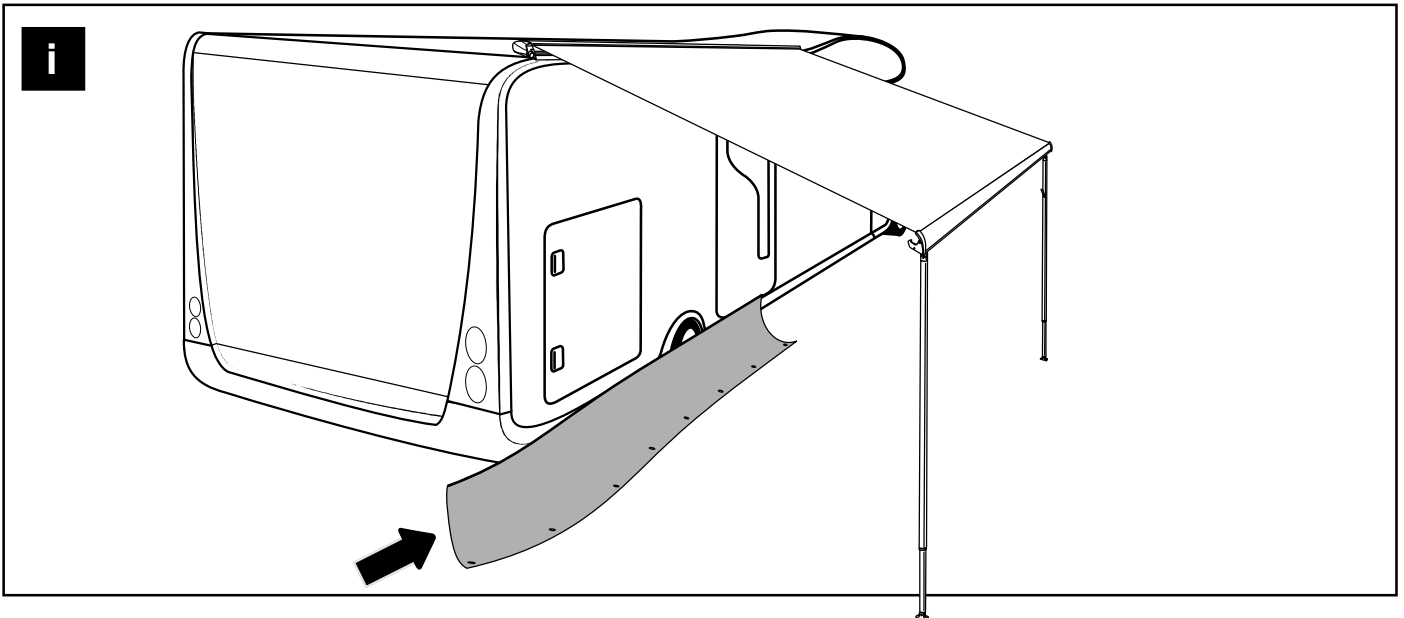
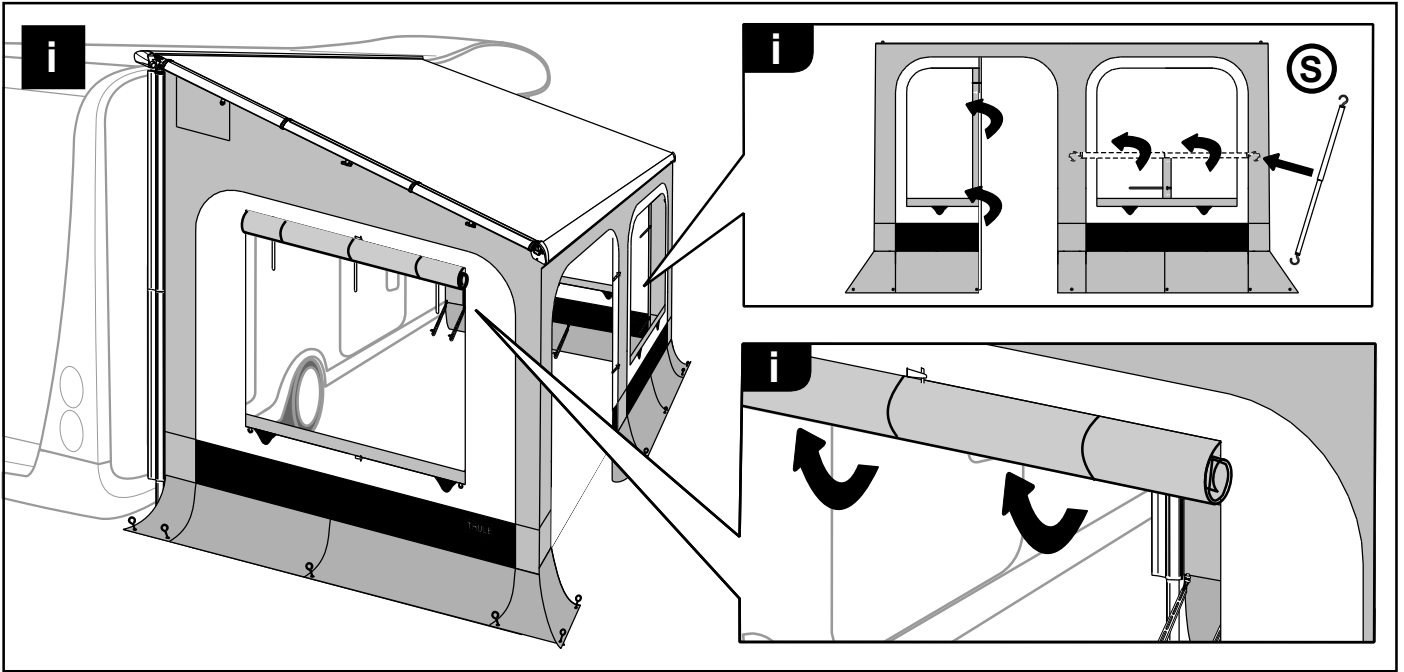

NL Algemene opmerkingen – Veiligheidsinstructies

1. Lees deze montage instructies aandachtig. Bij verkeerde montage of gebruik vervalt elke aanspraak op garantie.
2. Controleer vooraf of de geleverde Panorama past bij het type, de lengte en de uitval van de luifel. Kijk na of de hoogte van de zijwanden overeenkomt met de plaatsingshoogte van de luifel (hoogte tussen de grond en onderkant kast). Kijk na of het aantal en de lengte van de profielen overeenkomt met de plaatsingshoogte en uitval van de luifel.
3. Zorg ervoor dat het voertuig horizontaal staat.
4. Hou volgende regels in acht voor het kleven van de positieblokken in de luifelkast:
 - Het oppervlak moet droog, stof en vetvrij zijn!
 - Goed aandrukken! 72u wachten alvorens te belasten!
5. Zorg ervoor dat bij het plaatsen van de spanarm het luifeldoek overal netjes in de klemmen zit alvorens de luifel dicht te draaien! Span het luifeldoek strak aan met de zwengel of motor, zodat de spanarm goed opgespannen staat. Let hierbij op dat de spanarmen goed gepositioneerd zijn in de kast (positieblokken).
6. Kijk vóór het plaatsen van de mastprofielen na of de voertuigwand en de rubber afdichtflappen proper zijn. Zand, stof of vuil zou schade kunnen veroorzaken aan uw voertuig. Bij langdurige opstelling ook tussentijds reinigen.
7. Bij regen: zet één kant van de luifel wat lager zodat het water kan aflopen. De steunarmen altijd bijregelen met losgeschroefde klemmen om schade aan het luifeldoek te voorkomen!
8. Bij het opvouwen van de wanden, de ruiten niet vouwen!

EN General Remarks - Safety Instructions

1. Read these installation instructions carefully. No guarantee will be given for wrong installation or wrong use.
2. Check if the delivered Panorama matches the existing awning regarding type, length and extension. Check if the height of the side panels corresponds to the mounting height of the awning (height between the ground and the underside of the box). Check if the number & length of the delivered profiles match the existing awning regarding mounting height and extension.
3. Make sure the vehicle stands horizontally.
4. When attaching the positioning pieces in the main housing of the awning, respect the following rules:
 - The surface has to be dry and clean, no dust, no grease!
 - Press good! Please wait 72h before usage!
5. When placing the tension rafter, make sure the fabric is well placed between the clamps before you wind in the awning. Tighten the awning by hand or motor so there is a proper tension to the tension rafter. Make sure the tension rafter is well positioned in the awning box (positioning pieces).
6. Before installing the mast profiles, make sure that the vehicle wall and the rubber flaps are clean. Any sand, dust or dirt could damage your vehicle. When installed during a longer period, also clean them in between.
7. When raining, lower one side of the awning so that the water can run down the fabric. Always adjust the support legs with unscrewed clamps to avoid damage on the awnings fabric!
8. Never fold the windows when storing the canvas!

FR Remarques generales - Instructions de sécurité

1. Lisez cette notice attentivement. Un usage ou montage fautif annule toutes les clauses de garantie.
2. Contrôlez d'abord si le Panorama convient à votre store quant au type, longueur et avancée. Vérifiez si la hauteur du Safari Résidence correspond à la hauteur de montage du store (hauteur entre sol et dessous du boîtier du store). Contrôlez si le nombre et la longueur des profils correspond à la hauteur de montage et l'avancée du store.
3. Veillez à ce que le véhicule soit positionné horizontalement.
4. Pour fixer la pièce de positionnement à l'intérieur du boîtier, respectez les règles suivants :
 - La surface doit être sèche, dégraissée et dépoussiérée!
 - Bien appuyer! Attendre 72h avant d'y mettre une charge!
5. En plaçant le tendeur, veillez à ce que la toile du store soit bien prise en pincement sur toute la longueur du tendeur avant de tendre la toile du store à l'aide de la manivelle/moteur de façon que le tendeur soit bien tendu. Faites attention à ce que les supports tendeur soient placés correctement dans le boîtier du store (pièces de positionnement).
6. Vérifiez à ce que la paroi de votre véhicule et le double caoutchouc d'éanchéité soient bien propres avant d'installer les mâts de votre Safari Résidence. Le sable, la poussière ou la saleté pourraient endommager votre véhicule. Régulièrement nettoyer en cas de montage de longue durée.
7. En cas de pluie : baissez un des pieds du store pour que l'eau puisse s'écouler. Déclipsez toujours les profils tendeur avant de régler la hauteur des pieds de support afin d'éviter que la toile ne soit abîmée!
8. Pour le stockage, faites attention à ne pas plier les fenêtres.

DE Allgemeine bemerkungen – Sicherheitsvorschriften

1. Bitte lesen Sie diese Montagevorschriften aufmerksam, da bei unsachgemäßer Montage oder Anwendung die Garantie verfällt.
2. Überprüfen Sie vor dem Aufbau, ob der gelieferte Panorama mit dem Markisentyp, Länge und Auszug der vorhandenen Markise übereinstimmt. Überprüfen Sie, ob die Höhe der Seitenwände mit der Montagehöhe der Markise übereinstimmt (Höhe zwischen Boden und Unterkante des Markisengehäuse). Überprüfen Sie, ob die Zahl und die Länge der Schienen mit der Montagehöhe und den Auszug der Markise übereinstimmen.
3. Stellen Sie Ihr Fahrzeug horizontal auf.
4. Achtung bei das kleben der Positionierungsstück im Gehäuse der Markise:
 - Die Oberfläche muss Trocken, Staub- und Fettfrei sein!
 - Gut andrücken! 72 Stunden warten vor Belastung!
5. Bei der Montage der Klemmprofile, sorgen Sie dass Ihr Markisentuch sorgfältig in den Klemmprofile geschoben worden vor Sie die Markise zurückdrehen. Spannen Sie jetzt das Markisentuch an mit der Kurbel oder mit dem Motor, damit der Spannarm gut aufgespannen wird. Achten Sie hierbei darauf dass die Klammern gut positioniert worden sind im Markisengehäuse (Positionierungsstück).
6. Vor der Montage, bitte kontrollieren dass die Seitenwände des Fahrzeugs und die Mastprofile gesäubert sind. Sand, Staub oder Verschmutzungen können Schaden verursachen am Fahrzeug. Beim längeren Gebrauch des Residence G2, bitte auch zwischenzeitlich säubern.
7. Bei Regen: Stellen Sie ein Stützbein bedeutend tiefer, als das andere. Regeln Sie die Stützbeine immer mit aufgeschraubten Klemmprofile um Schaden am Markisentuch vorzubeugen!
8. Vermeiden Sie ein Knicken der Fenster, wenn Sie die Seitenwände und die Front aufrollen.

Various**Curtains**

| Set | Model | art. nr. | Colour | Awning length | |
|-----|---------------------------|----------|--------|---------------|------|
| | | | | From | To |
| I | Thule safari residence G2 | 309602 | Grey | 3m00 | 3m25 |
| | | 309603 | Blue | 3m00 | 3m25 |
| II | Thule safari residence G2 | 309605 | Grey | 3m50 | 4m00 |
| | | 309606 | Blue | 3m50 | 4m00 |
| | Thule safari panorama | 309605 | Grey | 3m00 | 3m50 |
| | | 309606 | Blue | 3m00 | 3m50 |
| III | Thule safari residence G2 | 309608 | Grey | 4m50 | 5m00 |
| | | 309609 | Blue | 4m50 | 5m00 |
| | Thule safari panorama | 309608 | Grey | 4m00 | 5m00 |
| | | 309609 | Blue | 4m00 | 5m00 |
| IV | Thule safari residence G2 | 309611 | Grey | 5m50 | 6m00 |
| | | 309612 | Blue | 5m50 | 6m00 |
| V | Thule safari panorama | 309886 | Grey | 5m50 | 6m00 |
| | | 309887 | Blue | 5m50 | 6m00 |

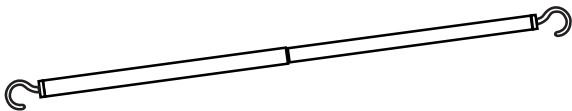
1500600119**Windowtube****307916****Hold down side strap kit****308247****Universal rafter****306778****3th Support leg**